

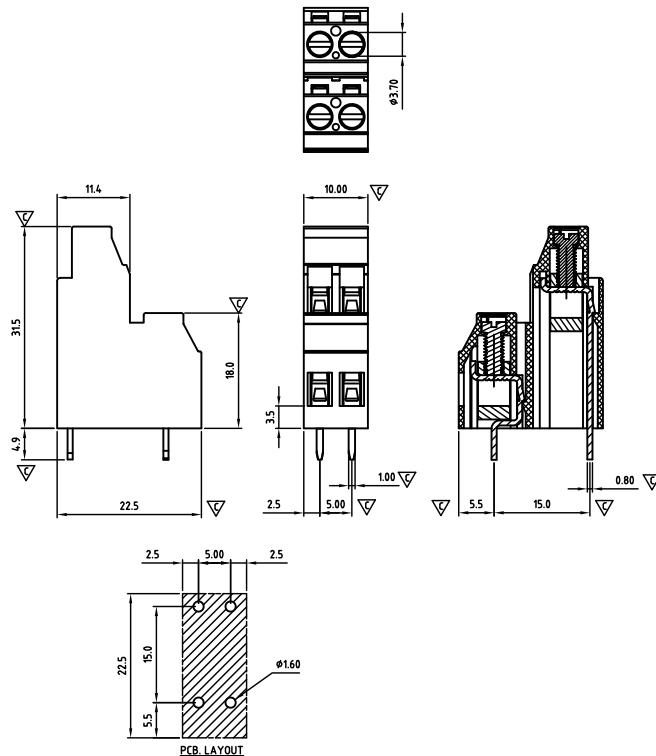

CAFGHM500-SERIES

Pitch 5,00mm



Tolerance	
x.	+/- 0,50
x.x	+/- 0,30
x.xx	+/- 0,10
x°	+/- 1°

Units:mm

Technical data

Technical data in accordance with UL/CUL

	Use Group	B	C	D
Nominal voltage (V)		300	-	300
Nominal current (A)		20	-	10
Connection capacity(AWG)		30-12	-	30-12

Technical data in accordance with IEC

Rated insulation voltage at pollution degree 2 (V)	400		
Rated current/conductor cross-section (A/mm ²)	24 / 2.5		
Solid/stranded(mm ²)	0.2-4 / 0.2-2.5		
Surge voltage category/pollution degree	III / 3	III / 2	II / 2
Rated insulation voltage(V)	250	400	630
Rated surge voltage(kV)	4	4	4

General data

Stripping length(mm)	7-8
Screw thread	M3.0
Tightening torque(Nm)	0.5-0.6
Insulation Withstanding Voltage	AC 1600 / 1min
Insulation Resistance	1000M Ω or more at DC500V
Using temperature range	-40°C-115°C

Materials

Insulation material group	PA 66 I UL94 -V0
Contact	Brass, Tin plated
Cage	Brass, Ni plated
Screw	Steel, Zn plated

Packing information

Poles	Order Number	SPQ
2*2	CAFGHM50804x000	110

Ordering code

CAFG HM 500 xx x XXX

① ② ③ ④ ⑤ ⑥

- ① Type
- ② Product style
- ③ Pitch
- ④ Poles (04)
- ⑤ Color
- ⑥ Standard 000 or Custom XXX

Color

0 Black	5 Green
1 Brown	6 Blue
2 Red	G Pale grey
3 Orange	8 Dark grey
4 Yellow	9 White

Key Commercial data

Custom tariff number 8536901000

Country of origin CN (China)

