

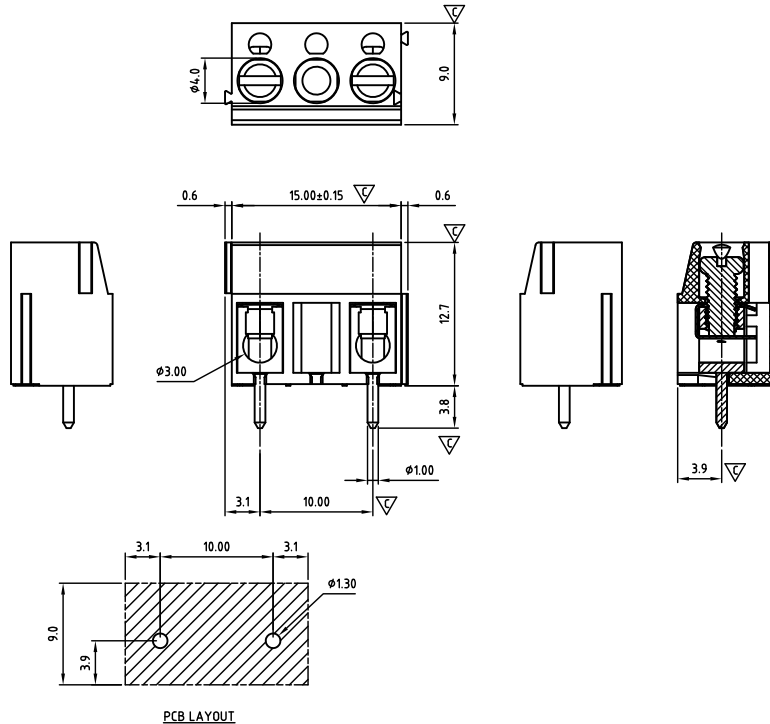

PCB Screw Wire protector System

CADAHM500-SERIES

cULus E501953



Tolerance	
x.	+/- 0,50
x.x	+/- 0,30
x.xx	+/- 0,10
x°	+/- 1°
	Units:mm

Pitch 5,00mm

Technical data

Technical data in accordance with UL/cUL

	Use Group	B	C	D
Nominal voltage (V)		300	-	300
Nominal current (A)		16	-	10
Connection capacity(AWG)		26-14	-	26-14

Technical data in accordance with IEC and VDE

Rated insulation voltage at pollution degree 2 (V)	250		
Rated current/conductor cross-section (A/mm ²)	17.5 / 1.5		
Solid/stranded(mm ²)	0.5-2.5 / 0.5-2.5		
Surge voltage category/pollution degree	III / 3	III / 2	II / 2
Rated insulation voltage(V)	250	320	630
Rated surge voltage(kV)	4	4	4

General data

Stripping length(mm)	6-7
Screw thread	M3.0
Tightening torque(Nm)	0.4
Insulation Withstanding Voltage	AC 1600 / 1min
Insulation Resistance	1000MΩ or more at DC500V
Using temperature range	-40°C-115°C

Materials

Insulation material group	PA 66 I UL94 -V0
Wire guard	Stainless steel
Cage	Brass, Sn plated
Screw	Steel, Zn plated

Packing information

Poles	Order Number	SPQ
3	CADAHM50003x000	400

Ordering code

CADA HM 500 xx x xxx
① ② ③ ④ ⑤ ⑥

- ① Type
- ② Product style
- ③ Pitch
- ④ Poles (02-24)
- ⑤ Color
- ⑥ Standard 000 or Custom XXX

Color

0 Black	5 Green
1 Brown	6 Blue
2 Red	G Pale grey
3 Orange	8 Dark grey
4 Yellow	9 White

Key Commercial data

Custom tariff number	8536901000
Country of origin	CN (China)

