

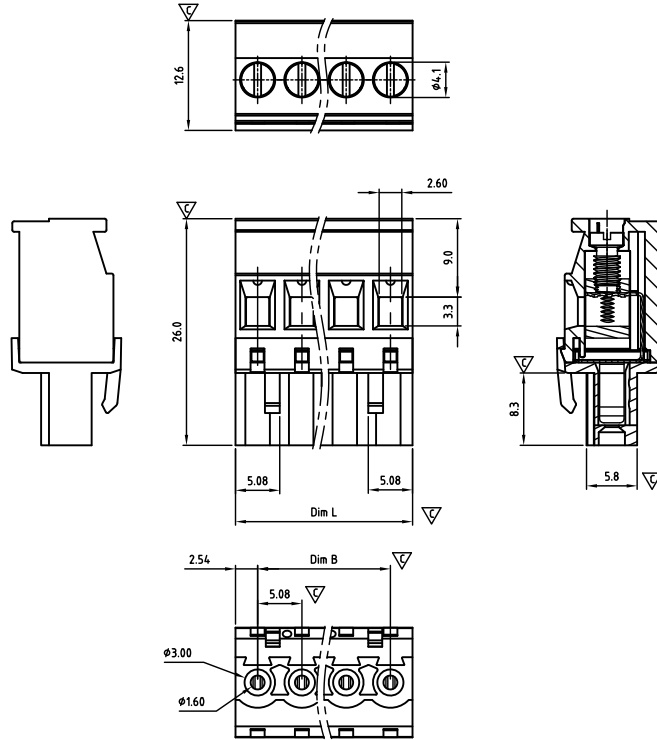

CAMBSR508-SERIES

cULus E501953



Critical dimension: ▽

Dim.L=Px5.08

Dim.B=(P-1)x5.08

P=Number of poles (02-24)

| | Dim B | Dim L |
|--------------|----------|----------|
| 0-30mm | +/- 0,15 | +/- 0,20 |
| over 30-60mm | +/- 0,20 | +/- 0,25 |
| over 60-90mm | +/- 0,25 | +/- 0,30 |
| over 90mm | +/- 0,30 | +/- 0,40 |

| Tolerance | |
|-----------|----------|
| x. | +/- 0,50 |
| x.x | +/- 0,30 |
| x.xx | +/- 0,10 |
| x° | +/- 1° |

Units:mm

Technical data

Technical data in accordance with UL/CUL

| | Use Group | B | C | D |
|--------------------------|-----------|-------|---|-------|
| Nominal voltage (V) | | 300 | - | 300 |
| Nominal current (A) | | 15 | - | 10 |
| Connection capacity(AWG) | | 30-12 | - | 30-12 |

Technical data in accordance with IEC and VDE

| | | | |
|--|-------------------|---------|--------|
| Rated insulation voltage at pollution degree 2 (V) | 320 | | |
| Rated current/conductor cross-section (A/mm ²) | 12 / 2.5 | | |
| Solid/stranded(mm ²) | 0.2-2.5 / 0.2-2.5 | | |
| Surge voltage category/pollution degree | III / 3 | III / 2 | II / 2 |
| Rated insulation voltage(V) | 250 | 320 | 630 |
| Rated surge voltage(kV) | 4 | 4 | 4 |

General data

| | |
|---------------------------------|--------------------------|
| Stripping length(mm) | 6-7 |
| Screw thread | M3 |
| Tightening torque(Nm) | 0.5-0.6 |
| Insulation Withstanding Voltage | AC1600V / 1min |
| Insulation Resistance | 1000MΩ or more at DC500V |
| Using temperature range | -40°C-115°C |

Materials

| | |
|---------------------------|------------------|
| Insulation material group | PA 66 I UL94 -V0 |
| Wire guard | PhBz, Tin plated |
| Cage | Brass, Ni plated |
| Screw | Steel, Zn plated |

Packing information

| Poles | Order Number | SPQ |
|-------|-----------------|-----|
| 2 | CAMBSR50802x000 | 250 |
| 3 | CAMBSR50803x000 | 165 |
| 4 | CAMBSR50804x000 | 130 |
| 5 | CAMBSR50805x000 | 110 |
| 6 | CAMBSR50806x000 | 90 |
| 7 | CAMBSR50807x000 | 84 |
| 8 | CAMBSR50808x000 | 80 |
| 9 | CAMBSR50809x000 | 70 |
| 10 | CAMBSR50810x000 | 55 |
| 11 | CAMBSR50811x000 | 55 |
| 12 | CAMBSR50812x000 | 55 |
| 13 | CAMBSR50813x000 | 50 |
| 14 | CAMBSR50814x000 | 45 |
| 15 | CAMBSR50815x000 | 35 |
| 16 | CAMBSR50816x000 | 35 |
| 17 | CAMBSR50817x000 | 35 |
| 18 | CAMBSR50818x000 | 35 |
| 19 | CAMBSR50819x000 | 35 |
| 20 | CAMBSR50820x000 | 35 |
| 21 | CAMBSR50821x000 | 25 |
| 22 | CAMBSR50822x000 | 25 |
| 23 | CAMBSR50823x000 | 25 |
| 24 | CAMBSR50824x000 | 25 |

Ordering code

CAMB SR 508 xx x xxx
① ② ③ ④ ⑤ ⑥

- ① Type
- ② Product style
- ③ Pitch
- ④ Poles (02-24)
- ⑤ Color
- ⑥ Standard 000 or Custom XXX

Color

| | |
|----------|-------------|
| 0 Black | 5 Green |
| 1 Brown | 6 Blue |
| 2 Red | G Pale grey |
| 3 Orange | 8 Dark grey |
| 4 Yellow | 9 White |

Key Commercial data

| | |
|----------------------|------------|
| Custom tariff number | 8536901000 |
| Country of origin | CN (China) |

Mating with headers

CAHAAH508 Series



CAHAAV508 Series



CAHABH508 Series

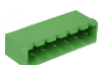

CAHABV508 Series



CAHAEH508 Series



CAHAEV508 Series

